

*Inflates around the trailer providing an effective seal for a variety of trailer sizes.*

## Benefits

- SAVE hundreds of dollars in reduced energy costs
- IMPROVE working conditions & by keeping dust, dirt, debris insects out
- PROTECT product & personnel from harsh weather conditions
- INCREASE PRODUCTIVITY by providing a safe & comfortable working environment
- DURABLE range of Hi-Performance fabrics to choose from
- CUSTOM sizes available



### Standard Size Specifications

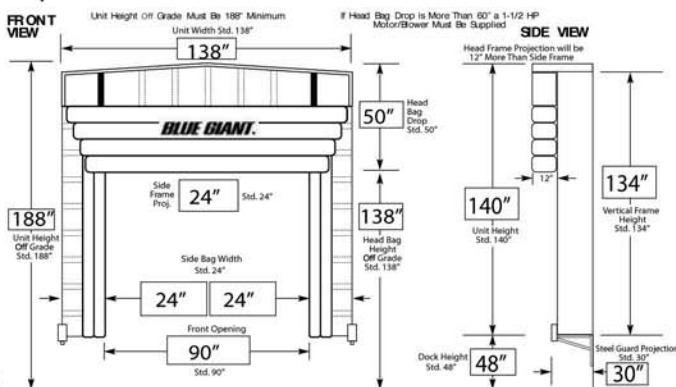

Generally designed to suit 10' wide x 10' high openings.

The series BG450IS service a large variety of trailer heights. This unit allows full access to the rear of the trailer when loading and unloading. An internal oil tempered spring on the header air bag and counter weight retraction design on the vertical bags allows the top and side air bags to fully retract when not in use.

This design prevents damage from incoming trailers since the unit is inflated after the trailer has docked and deflated before trailer departs.

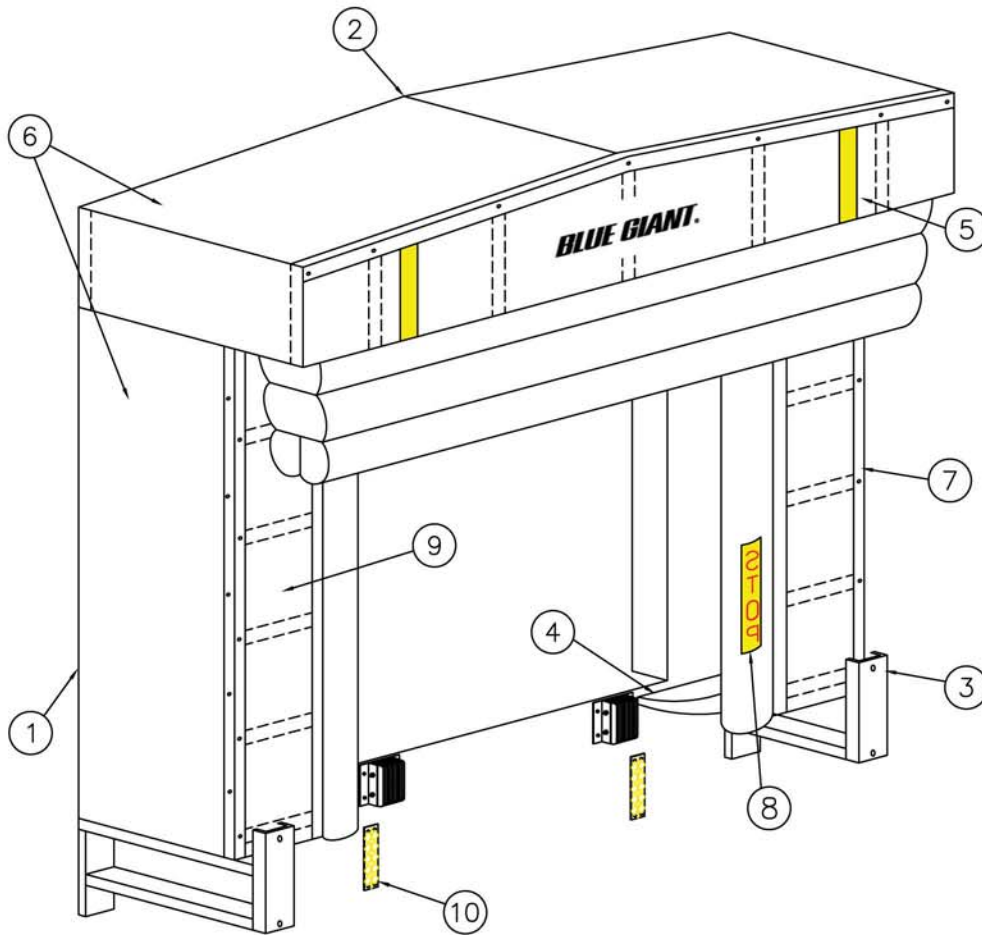

- 1 Pressure treated framing resists rot (optional galvanized frame available)
- 2 Raked head frame diverts water to sides
- 3 Protective steel guards
- 4 Replaceable foam bottom pads seal gap between truck and building wall
- 5 Yellow guide stripe ensures accurate placement of trucks
- 6 Translucent polyethylene sheeting with UV inhibitors allows light into loading dock area
- 7 Galvanized trim angle will not rust
- 8 "Stop" logo on side air bag to prevent trailer from entering dock area if bag is accidentally left inflated
- 9 Air bag storage curtains prevent damage to air bag when retracted by any misaligned trailer
- 10 Optional "Reflective Guides" ensure accurate truck placement and help to protect frame from misaligned trailers

### Fabric & Colour Selection

Blue Giant can customize your dock seal with the ideal fabric for your application from a wide range of colours and fabrics available.

- 22 oz Hi-Tear Vinyl
- 32 oz Hi-Tear Vinyl
- 40 oz Hi-Tear Vinyl
- Hi-Performance Arctic Seal
- 16 oz Hi-Tear Hypalon
- 40 oz Hi-Performance Hypalon

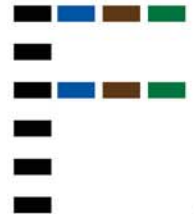

### Conventional Seal



(Top View)

Foam pads protect against weather, but restricts access to the trailer opening.

### Inflatable Shelter



(Top View)

Provides full access to the rear of the trailer.



85 Heart Lake Road South  
 Brampton, Ontario, Canada L6W 3K2  
 Phone: 905-457-3900 • Fax: 905-457-1509  
[www.BlueGiant.com](http://www.BlueGiant.com)

AUTHORIZED DISTRIBUTOR

BLUE GIANT EQUIPMENT CORPORATION