

# THERMASEAL™



ThermaSeal TM175 with full-view windows

M A X I M U M

T H E R M A L

P R O T E C T I O N



# THERMASEAL™

## SECTIONAL THERMAL DOORS

For maximum thermal protection, choose ThermaSeal™, our durable, energy-efficient sectional door. Our exclusive process fills 100% of the door's interior space with energy-saving polyurethane foam insulation to deliver exceptional R-values. This process also provides superior foam density for excellent structural integrity.

### THERMASEAL™ TM200

The ultimate choice for thermal protection is the ThermaSeal TM200. With an R-value of 18.3, this 2" thick model is the most energy efficient in the ThermaSeal line. With all the standard features you expect from a ThermaSeal door, the TM200 is a great fit for a variety of applications demanding performance.

### THERMASEAL™ TM175-20

The choice for durability and thermal efficiency in challenging environments is the ThermaSeal TM175-20. With a heavy duty 20-gauge exterior and a 16.4 R-value, this 1-3/4" thick model has all the features you expect and options you need for a wide range of applications.

### THERMASEAL™ TM175

With a 16.4 R-value, this benchmark product provides proven Raynor reliability and durability to meet or exceed the requirements of daily use. This door is offered with the widest selection of quality features and options for the most common product applications.

## BUILT TOUGH.

Rust-resistant galvanized steel is finished with a two-coat, baked-on paint process for long life. The superior thermal bond between steel and polyurethane foam is warranted against delamination for 10 years.



ThermaSeal TM175, white, with rectangular windows

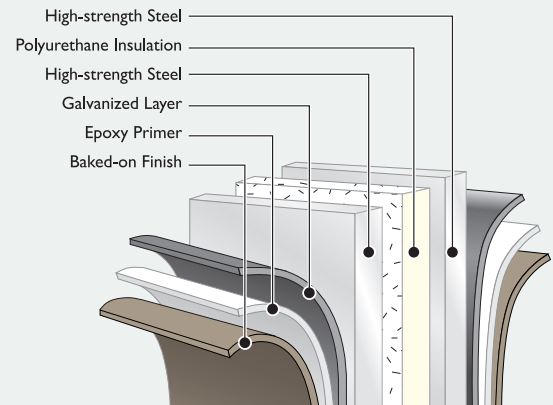

Series MODEL	Max. Opening Width	Max. Opening Height	Construction	Surface Texture	Section Thickness	Exterior/Interior Steel Thickness	End Style Steel Thickness	Insulation (R-Value)	Thermal Break	Exterior Colors	Section Warranty*
ThermaSeal TM200	36'	22'	Steel Sandwich	Stucco	2"	26-Gauge (.013"min.)/ 26-Gauge (.013"min.)	16-Gauge (.055" min.)	Polyurethane Foam (18.3)	Yes	White	1-Year (Any Rust) 10-Year (Delamination)
ThermaSeal TM175-20	24'	22'	Steel Sandwich	Stucco	1 3/4"	20-Gauge (.035"min.)/ 26-Gauge (.013"min.)	16-Gauge (.055" min.)	Polyurethane Foam (16.4)	Yes	White	1-Year (Any Rust) 10-Year (Delamination)
ThermaSeal TM175	36'	22'	Steel Sandwich	Stucco	1 3/4"	25-Gauge (.018"min.)/ 26-Gauge (.013"min.)	16-Gauge (.055" min.)	Polyurethane Foam (16.4)	Yes	White, Dark Brown	1-Year (Any Rust) 10-Year (Delamination)

\***WARRANTY** ThermaSeal door sections carry a 1-year limited warranty against any rust and a 10-year limited warranty against delamination (of the steel door skins from the insulating foam). Hardware and springs are warranted for 1 year against defects in materials and workmanship. See your local Raynor Dealer for complete details.

THERMASEAL FEATURES



**Maximum thermal protection.**

Energy-saving polyurethane foam insulation is used to deliver exceptional R-values.



**Rugged hardware and springs.**

Your ThermaSeal door comes packaged with the right combination of long-lasting hardware, track and springs to precisely match your door's size and application.



**Reduced airflow.**

Dual vinyl barriers dramatically reduce air infiltration. A true thermal break prevents heat loss and eliminates any metal-to-metal contact between surfaces.



**Decreased energy costs.**

ThermaSeal doors help you reduce energy costs with a U-shaped, vinyl bottom weatherseal and sturdy aluminum retainer.



VISIT US AT [WWW.RAYNOR.COM](http://WWW.RAYNOR.COM) FOR  
CSI MASTER FORMAT™ SPECIFICATIONS,  
RAYNOR QUICK SPECS  
AND STANDARD DRAWINGS

APPLICATION GUIDE

	ThermaSeal TM200	ThermaSeal TM175-20	ThermaSeal TM175
Agricultural Buildings	●	●	●
Car Wash/Corrosive Environments	◐	◐	◐
Commercial/Multi-Tenant	●	●	●
Fire Station/Ambulance	●	●	●
High Security	●	●	●
Large Opening Size	●	●	●
Mining, Pulp & Paper	◐	●	◐
Non-insulated Storage	○	○	○
Service Station	◐	●	◐
Thermal Environments	●	●	●
Transit Facility/Truck Terminal	●	●	●
Underground Parking	○	○	○
Warehouse/Manufacturing	●	●	●

● Best Choice ◐ Good Solution ○ Applicable

MODEL OPTIONS AND UPGRADE



**Choice of windows.**

Select either 24" x 8" (shown), 24" x 12", or 34" x 16" rectangular 2 piece rigid frame, 34" x 16" rectangle or aluminum full-view window sections. Choose from a variety of insulated glass, acrylic, tempered and polycarbonate styles to suit any application.



**Locks.**

In applications where control and access are important, choose from a variety of locking options to help keep your building secure. Locks come in both inside and outside variations.



**Customized track and hardware systems.**

Track systems are supplied to fit special clearances, inclines or contour applications. Hardware and track systems can be designed to fit any need.\* Additional trussing is available for special windloading applications.



**Pedestrian doors.**

Pedestrian doors are designed for convenient entry and to help minimize energy loss.\*



**Removable center posts.**

Carry-away and swing-up options are available for extra-wide openings. Ideal for agricultural or airplane hangar applications.



**Carbon monoxide vent.**

Allows you to channel fumes to the outside when door is closed. Available in a variety of sizes.



**High-cycle counterbalance systems.**

For reliable operation in high-traffic areas, choose high-cycle torsion springs with 25,000, 50,000 or 100,000-cycle life.\* For reduced maintenance and ultra-smooth operation in heavy-use applications, choose a weight counterbalance system.

\*Some options may be limited to door size or model. Contact your local Raynor Dealer regarding availability for your application.



P.O. Box 448, 1101 EAST RIVER ROAD, DIXON, IL 61021



CLICK  
WWW.RAYNOR.COM

CALL  
1-800-4-RAYNOR

FAX  
1-815-288-7142

Exclusively Distributed By:

This information was as complete and factual as possible at the time it was printed. We do, however, reserve the right to make changes in product specifications and availability without notice. Features and options may be different in countries other than the United States. Product colors have been reproduced as well as possible with present commercial printing processes. For absolute accuracy in color matching, use actual product samples.